

## Pinces tirées - Zugspannzangen - Pull-type collets

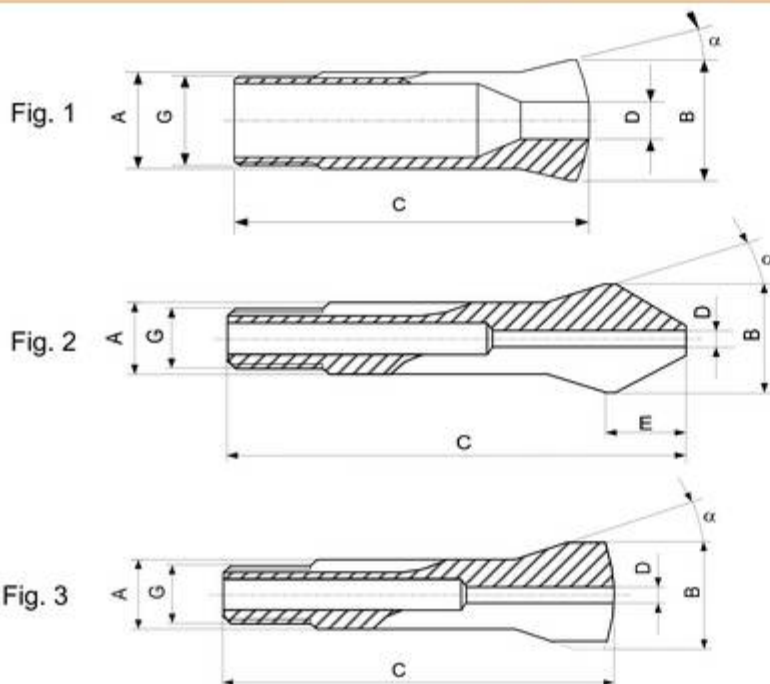

Alésage à cran  
Stufenbohrung  
Step bore

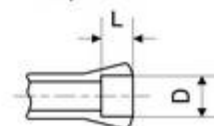

Obturbateurs pour pinces, voir page 70  
Dichtgummi für Spannzangen auf Seite 70  
Rubber seals for collets on page 70

Type	Art.	A	B	C	E	G	$\alpha$	D min-max	L	Fig.
B6	72-128	6	10.5	31.3	-	$\emptyset 5 \times 0.706 \nabla 55^\circ$	$20^\circ$	0.30...3.00	-	1
								3.01...4.50	12	
								4.51...5.00	4.5	
								5.01...5.50	4	
								5.51...6.00	3.5	
72-1897 26)	6	9	31.3	-	$\emptyset 5 \times 0.706 \nabla 55^\circ$	$20^\circ$	0.30...3.00	-	3	
							3.01...4.50	12		
							4.51...5.00	4.5		
							5.01...5.50	4		
							5.51...6.00	3.5		
B8	72-137	8	13	35.5	-	$\emptyset 6.82 \times 0.625 \nabla 55^\circ$	$20^\circ$	0.30...4.00	-	1
								4.01...6.50	13	
								6.51...7.00	6	
								7.01...7.50	5	
								7.51...8.00	4	
								8.01...8.50	3.2	
								8.51...9.00	2.5	
								9.01...9.50	1.7	
								9.51...10.00	1	
								72-1898 26)	8	
4.01...6.50	12.5									
6.51...7.00	6									
7.01...7.50	5									
7.51...8.00	4									
72-95	8	13	40.5	7	$\emptyset 6.82 \times 0.625 \nabla 55^\circ$	$20^\circ$	0.30...3.30	-	2	
							3.31...6.50	21		

Alésages standards (rond, carré, six-pans) selon liste de prix. Autres alésages sur demande.  
Standardbohrungen (rund, vierkant, sechskant) gemäss Preisliste. Andere Bohrungen auf Anfrage.  
Standard bores (round, square, hexagonal) according to price list. Other bores on request.  
26) Sur demande - Auf Anfrage - On request